

TYPE A-1
PRE-MOLDED OR SAWED LONGITUDINAL AND C&G JOINT

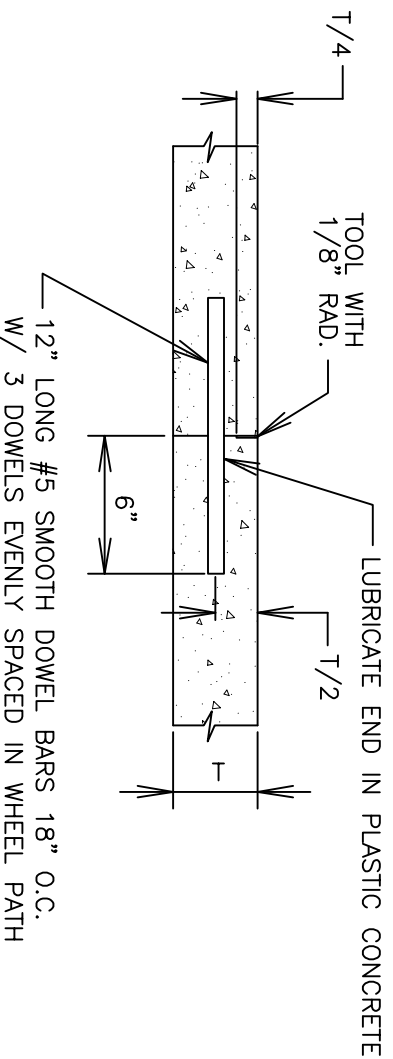

TYPE D
TRANSVERSE CONSTRUCTION JOINT

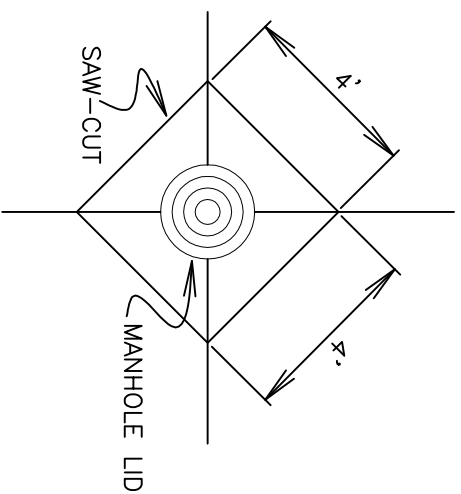

MANHOLE SAW-CUT DETAIL

P.C.C. PAVEMENT
JOINT DETAILS

CITY OF CAÑON CITY
ENGINEERING DEPARTMENT

STANDARD DETAIL

REMOVED, AUGUST 2008

S-12

*LOCAL ROAD MINIMUM
*SECTION TO BE DESIGNED/CONFIRMED BY GEOTECHNICAL ENGINEER AND APPROVED BY CITY.